

UniFlow[®] LE Dual Entry Fume Hoods

UniFlow LE Dual Entry Air Bypass Hoods are ideal for demonstrations or applications where observation and access is required from both sides of the fume hood. Dual Entry Hoods are available in 48", 60", 72", & 96" widths and in 30", 36" & 48" depths. They can be positioned on an island or in peninsular locations. Dual Entry Hoods can be also located on a common wall of two rooms with accessibility from either room.



UniFlow LE Dual Entry Hood Cat. No. 35631
shown with optional epoxy resin worksurface, fixtures, and base cabinets,

UniFlow Superstructure exclusive unitized dual wall construction for superior chemical resistance (**NO RUST**), strength, and durability. Meets NFPA-45 classification with flame spread of less than 25 per ASTM E-84.

Access Panel removable to access ducting connections and electrical services from a single point electrical box, 115/60Hz AC operation.

Full 28" Viewing Height Sash with 28" sash opening height for ease of access and viewing tall apparatus setup. Sash is 3/16 thick tempered safety glass, with chemical resistant non-metallic PVC framing, track, and aerodynamic sash lift (horizontal sash). Sash handle for efficient air flow and ease of movement. Standard horizontal sash, optional vertical sash, specify sash for each side.

Fume Chamber with coved corners. Surface is white, glass smooth for ease of cleaning and excellent light reflectivity.

Air Flow Monitor with Repeater (Optional equipment) flush mounted air flow Monitor for Dual Entry Fume Hoods only. It features a back lit display which displays the air flow velocity or Air flow status. **Cat No. 51405**

Plumbing Services fixtures are color coded to specific service. (Optional equipment)

Fume Hood Fire Extinguisher
(Optional equipment)

Epoxy or Phenolic Work Surfaces
(Optional equipment)

Fume Hood Base Cabinet
(Optional equipment)

SASH OPTIONS

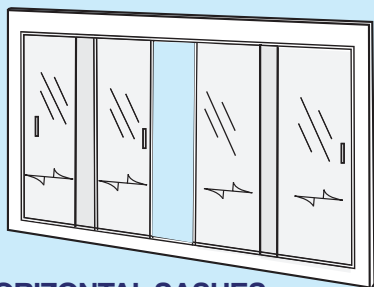

HORIZONTAL SASHES

The standard sash for HEMCO dual entry fume hoods. The maximum sash opening for the horizontal sash is 1/2 that of the vertical sashes. The smaller opening, means less air exhausted resulting in energy savings.

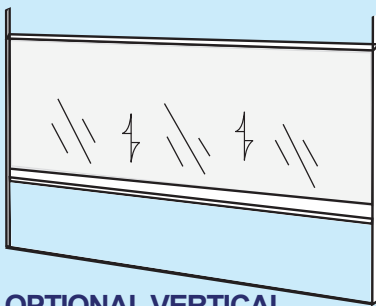

OPTIONAL VERTICAL SASHES

The optional sash for HEMCO dual entry fume hoods. The sash may be lifted to the completely open position for maximum access thru the fume chamber. Sash stops available.

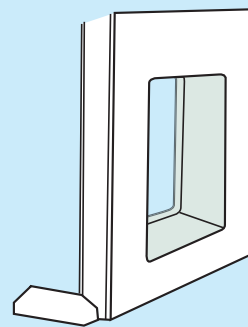

OPTIONAL SIDE VIEW WINDOWS

Can be installed on right or left sides.

Side View Window 16" X 20" - Cat. No. 51620

Side View Window 24" X 20" - Cat. No. 52420

HEMCO Corporation
711 S. Powell Road
Independence, MO 64056

HEMCO
Lab Planning Solutions

Phone (816) 796-2900
Fax (816) 796-3333
LE DUAL 06.18

UniFlow LE Dual Entry Fume Hoods

UNIFLOW LE DUAL ENTRY DESCRIPTIONS		Hood Depth "B"	FUME HOOD WIDTH "A"			
			48" Cat.No.	60" Cat.No.	72" Cat.No.	96" Cat.No.
1. LE Dual Entry Bypass CAV Hood: Superstructure to be modular composite chemical resistant FRP non-metal construction. Interior fume chamber to be glass-smooth with bell shaped exhaust collar. Picture frame sash opening in front with (4) horizontal moving sashes constructed of clear tempered safety glass with chemical resistant framing and track. Vapor proof light fixture and control switch are wired to a single point junction box. 115/60Hz, AC All electrical components are U.L. listed. Optional electrical services.		30"	35431	35531	35631	35831
		36"	35441	35541	35641	35841
		48"	35451	35551	35651	35851
2. Vertical Moving Sash Option: Add suffix to catalog number. Includes sash stops at 1/2 open position.			VS-4	VS-5	VS-6	VS-8
3. Epoxy Resin Worksurface: ideal for high concentrations of solvents, acids and alkalis. Excellent scratch and wear resistance. Dished to contain spillage. 1 -1/4" thick, color: black.		30" deep worksurface	20435	20535	20635	20835
		36" deep worksurface	20455	20555	20655	20855
		48" deep worksurface	20445	20545	20645	20845
4. 30" Base Cabinet Assembly: Consists of cabinet(s) & 8" filler panels of top grade welded furniture steel. Cabinets include two hinged doors. (Side View A)		28" deep - cabinet access from one side only	50430	50530	50630	50830
5. 36" Base Cabinet Assembly: Consists of (2) cabinets & 14" filler panels of top grade welded furniture steel. Cabinets include two hinged doors. (Side View A)		34" deep - cabinet access from one side only	50436	50536	50636	50836
6. 48" Base Cabinet Assembly: Consists of (4) cabinets and 2" filler panels of top grade welded furniture steel. Cabinets include two hinged doors. (Side View B)		46" deep - cabinet access from both sides	50448	50548	50648	50848

Width "A"	48"			60"			72"			96"		
Width "C"	37"			49"			61"			85"		
Diameter "D"	10"			10"			12"			(2) 10"		
Depth "B"	30"	36"	48"	30"	36"	48"	30"	36"	48"	30"	36"	48"

Dual entry fume hoods are available with optional worksurface and support cabinets. The 30" deep model requires a standard with a finished rear panel assembly. 48" deep model requires two cabinets back-to-back plus filler panels, allowing cabinet access from both sides.

